

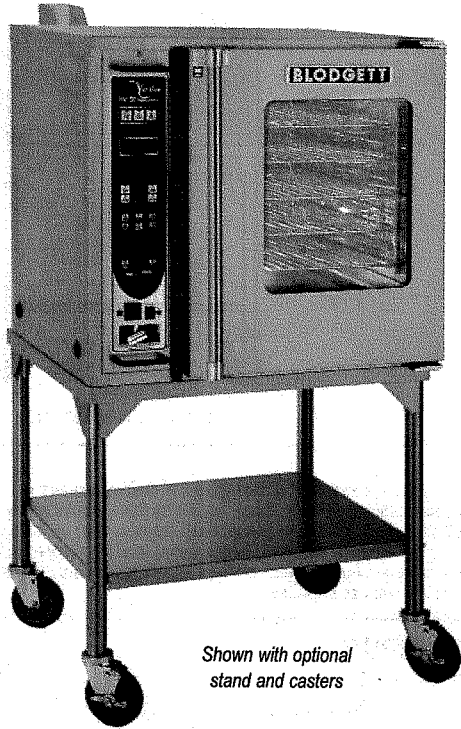

MODEL HV-50E
Half-Size Electric Oven

HV-50E



Shown with optional stand and casters

OPTIONS AND ACCESSORIES
(AT ADDITIONAL CHARGE)

- **Stands:**
 - 11" (286mm) stainless steel stand
 - 29" (737mm) stainless steel stand
- Extra stainless steel oven racks
- Additional core probe
- Side heat shield
- 480 VAC, 3 phase
- Water pressure regulator

Project _____

Item No. _____

Quantity _____

Standard depth baking compartment - accepts five 13" x 18" standard half-size baking pans in front to back positions.

All data is shown per oven section, unless otherwise indicated.

Refer to operator manual specification chart for listed model names:

EXTERIOR CONSTRUCTION

- Fully welded angle-iron frame
- Stainless steel front, top, sides and back
- Dual Plane tempered glass windows encased in a stainless steel door frame with hinged inner glass for easy cleaning
- Retractable hand shower for ease of cleaning

INTERIOR CONSTRUCTION

- 316 stainless steel liner for easy cleaning
- Two halogen interior lights
- Drain in oven cavity
- Hinged air pressure panel for easy cleaning
- Up to 2.5" of mineral board insulation for greater heat retention
- Three tubular heater element design

OPERATION

- MenuSelect control with 99 programs and 6 cooking stages
- Hydrovection cook mode with humidity control adjustable in 10% increments
- Hot air cook mode for baking and pastries
- One touch cooking
- Low temperature cooking and holding
- Four speed auto-reversing fan motor
- Thermostatically controlled quench system, Eco-Friendly

STANDARD FEATURES

- Core Temperature probe
- Retractable hose reel below control panel, no extraneous hoses
- USB port on the control panel for uploading and downloading Recipe files and HACCP information
- 95 dB beeper on the control panel to compete with even the loudest of kitchens
- Start-up inspection service by factory authorized service agent
- 1 year parts and 1 year labor warranty



BLODGETT OVEN COMPANY

www.blodgett.com

44 Lakeside Avenue, Burlington, VT 05401 • Toll Free: (800) 331-5842 • Phone: (802) 860-3700 • Fax: (802) 864-0183



MODEL HV-50E

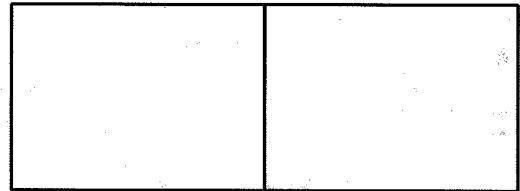

APPROVAL/STAMP

DIMENSIONS ARE IN INCHES (MM)

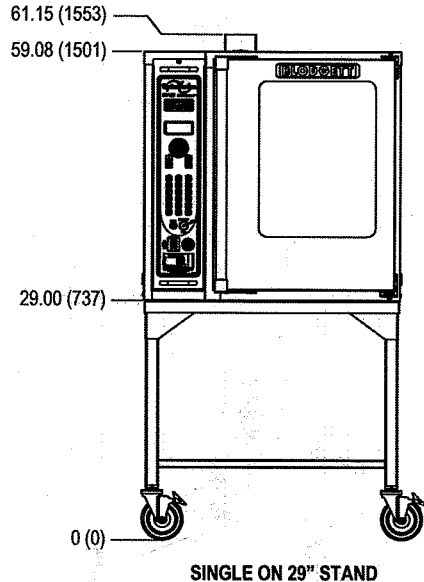
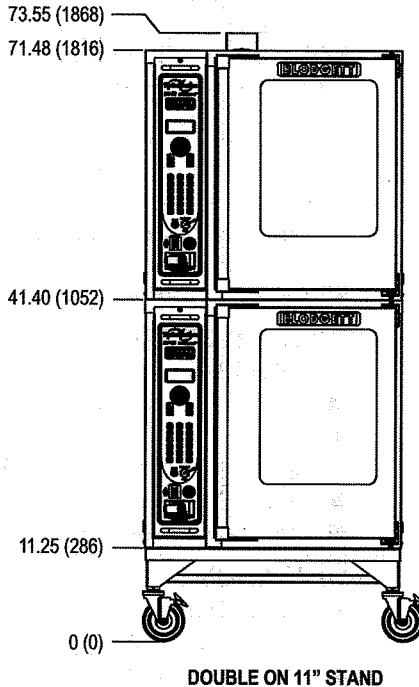
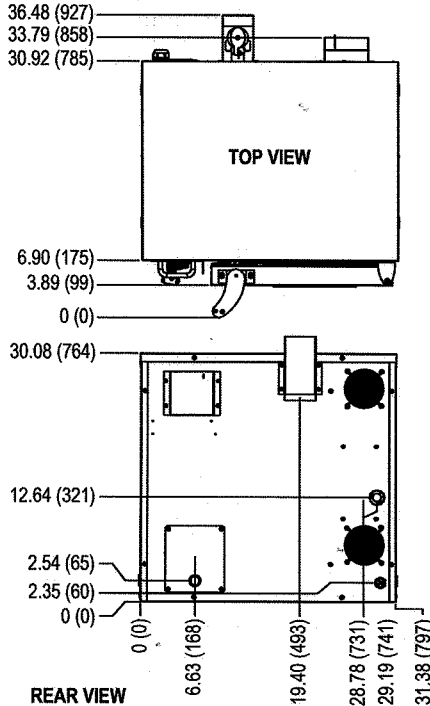

SHORT FORM SPECIFICATIONS

Provide Blodgett half-size hydrovection oven model HV-50E, (single/double) compartment with fully welded angle iron frame. Each compartment shall have 316 stainless steel liner. Unit shall accept five 13" x 18" standard half-size bake pans. Doors shall be stainless steel with dual pane thermal glass windows. Unit shall be electrically heated by three tubular elements. Air in baking chamber distributed by single inlet blower wheel powered by a multiple speed, reversing, 1/2 HP motor with thermal overload protection. Each chamber shall be fitted with bright halogen lamps, and five standard chrome-plated removable racks. Retractable hose reel mounted just below the control for easy cleanup. Control panel shall be programmable MenuSelect with moisture control, low temperature Cook and Hold and the ability to program up to 99 six stage recipes. Breaker shut off switch on front panel for easy service. Start-up inspection service by factory authorized service agent. 1 year parts and 1 year labor warranty. Provide options and accessories as indicated.

DIMENSIONS:

Floor space	31.38" (797mm) W x 36.48" (927mm) D
Interior	15.3" (389mm) W x 20.5" (521mm) H x 22" (559mm) D
Product clearance from combustible and non-combustible construction	
Oven sides	0" (0mm) Blodgett recommends 4" clearance from any heat source on the control panel side of the oven, an optional heat shield should be considered.
Oven back	0" (0mm)

WATER SUPPLY (per section):

Good quality water feed is the responsibility of the owner. Water quality must be within the following general guidelines.

TDS: < 100 ppm	Hardness: 80-120 ppm	pH: 7.0 - 8.0
Chlorides: < 30 ppm	30(min)-50(max) PSI	140°F (60°C) avg. drain temp.
1" NPT drain connection		3/4" garden hose cold water

The best defense against poor water quality is a water filter system designed to meet your water quality conditions. **Filtered water is highly advised.**

Water Consumption

Hydro Mode	1.5 GPH
------------	---------

Appliance is to be installed with backflow protection in accordance with Federal, State or Local codes.

MAXIMUM INPUT:

Single	13kW
Double	26kW (13kW each section)

POWER SUPPLY:

V.A.C.	Hz	Phase	kW	Amperes (L1-L2-L3)
208	60	3	13	38/38/34
240	60	3	13	30/30/28

1/2 H.P., 3 phase motor

MINIMUM ENTRY CLEARANCE:

Uncrated	32" (813mm)
Crated	36" (914mm)

SHIPPING INFORMATION:

Approx. Weight	
Per section	350 lbs. (159 kg)
Crate sizes	
	35-1/2" (902mm) x 42-1/2" (1079mm) x 37-1/2" (953mm)
	(2 crates required for double)

NOTE: The company reserves the right to make substitutions of components without prior notice

BLODGETT OVEN COMPANY

www.blodgett.com

44 Lakeside Avenue, Burlington, VT 05401 Toll Free: (800) 331-5842 • Phone: (802) 860-3700 • Fax: (802) 864-0183